

NARA

www.naracorp.com

ДИСКОВАЯ МУФТА



 **КУЗБАССТЕХНОСНАБ**
комплексные поставки промышленного оборудования

www.nara-russia.ru

ДИСКОВЫЕ МУФТЫ PANFLEX

Features



- NARA Panflex coupling is designed with an optimized structure that is competitive in various industrial fields.
- Stable torque transmission even in case shaft misalignment is unavoidable.
- Possible to manufacture couplings that meet API 671 code.
- Simple installation and easy inspection.
- Possible to assemble and disassemble without moving related machines.
- ⑥ Zero backlash and high torsional rigidity.

Structure

4 Bolts

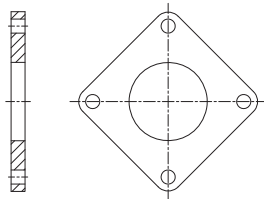

- Zero backlash
- Stainless Steel (SUS304)

6 Bolts

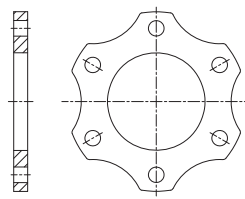

- Zero backlash
- Stainless Steel (SUS304)

8 Bolts

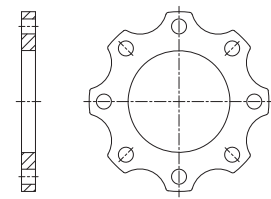

- Zero backlash
- Stainless steel (SUS304)

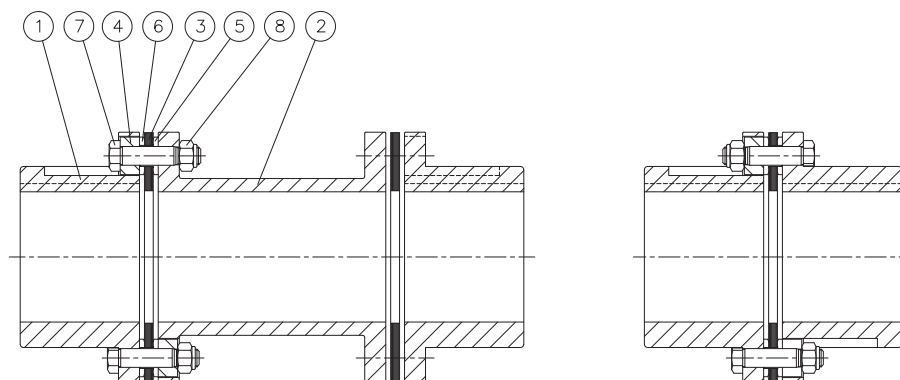

- | | | | |
|------------|-----------|----------------|--------------------|
| 1. HUB | 2. SPACER | 3. ELEMNT PACK | 4. OVERLOAD WASHER |
| 5. BUSHING | 6. WASHER | 7. REAMER BOLT | 8. NYLON NUT |

Selection

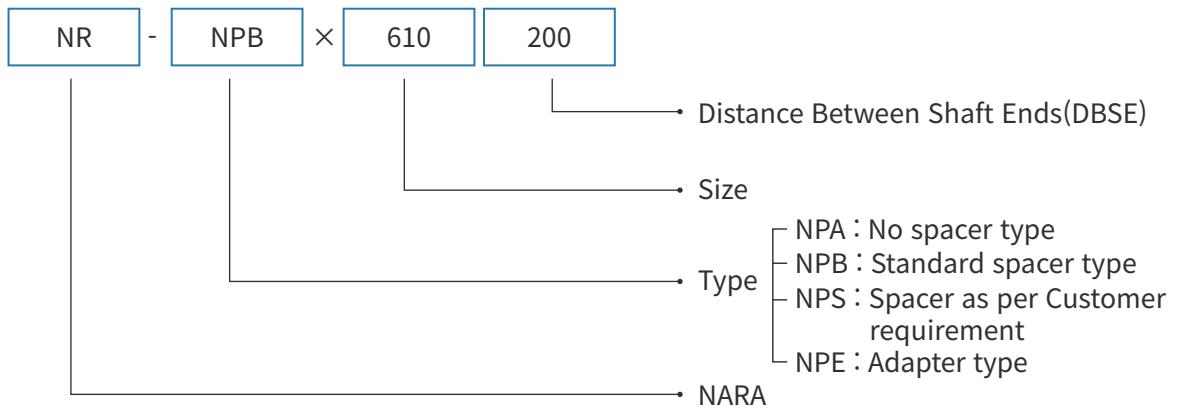

Step 1

- Calculation of required torque (Tw)

$$T_w \text{ (Nm)} = 9550 \times \frac{P \text{ (kW)}}{N \text{ (rpm)}}$$

P : Prime motor power(kW)
N : Coupling rotation speed(rpm)

Step 2

- Calculation of required torque (Tw)

$$T_r \text{ (Nm)} = T_w \text{ (Nm)} \times F_1$$

Determine Service factor(F_1) on page 86

Step 3

- Select size in which the rated torque (T_n) of the coupling size is larger than the required torque (T_r) in the dimension table.

$$T_n > T_r$$

Step 4

- Check whether max. bore diameter of the coupling meets the shaft diameter of the prime motor and driven machine.
- Check whether max. rotation speed of the coupling meets the rotation speed of the prime motor

Installation

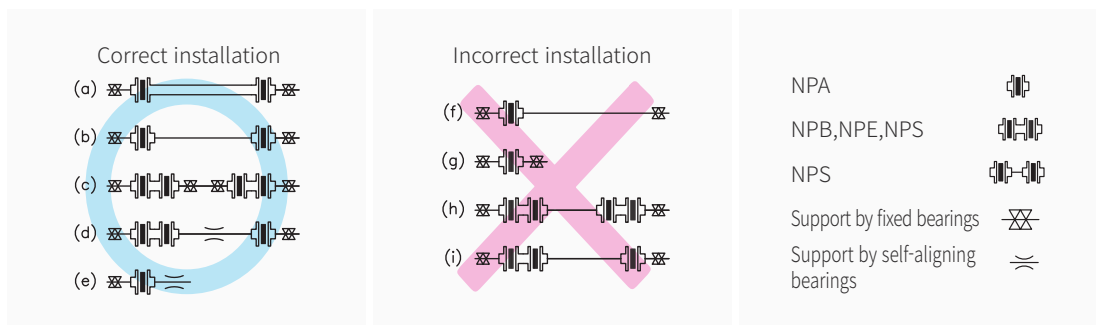

- Use NPA type coupling as shown in (b).
- When fitting the intermediate shaft to two pairs of NPB or NPS type, it has to be supported by fixed bearings as shown in (c).
- When using NPB / NPS type and NPA type together, it should be supported by self-aligning bearing to support inclined shaft as shown in (d).
- In case of mounting the couplings

without supporting bearings on the intermediate shaft as shown in (h) or (i), it rotates in inclined condition that can cause vibration.

- For operation in high-speed rotation allowable maximum rotation speed of the coupling can be slightly increased thru the accuracy of the shaft alignment and coupling balancing work.

Installation

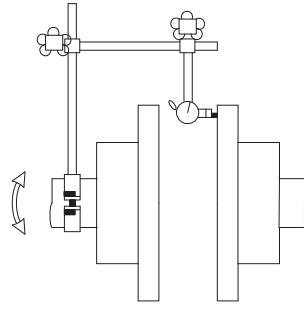

[Fig.1]

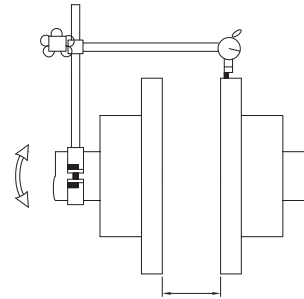

[Fig.2]

- Clean the shaft and the bore of flange and check if tolerance fits properly.
- When performing shrinkage fitting, heat the flange in oil bath at 120°C~150°C.
- For the distance between shaft ends refer to the dimensional table “G” or “DBSE” values.
- Check the lateral runout (ΔG) in Fig. 1 and align the shaft so that the lateral runout value is not more than the value as shown in Table 1.
- After checking the eccentricity in Fig. 2, find the lateral runout (ΔG) value due to the eccentricity (ΔE), and align the shaft so that the lateral runout value (ΔG) is within the value as shown in Table 1.
- After aligning the shaft, assemble the

spacer and element to the flange with bolts.

Do not apply excessive force when inserting the bolts.

- Tighten the nut with the provided torque as per Table 2.

• To maintain a long service life, recheck the shaft alignment within 2 hours after installation and trial run.

When reassembling, tighten nuts securely with the provided tightening torque value.

It is recommended to disassemble and reassemble nuts within 10 times.

For long-term usage of the coupling and to show its maximum capability, shafts must be well aligned when assembling.

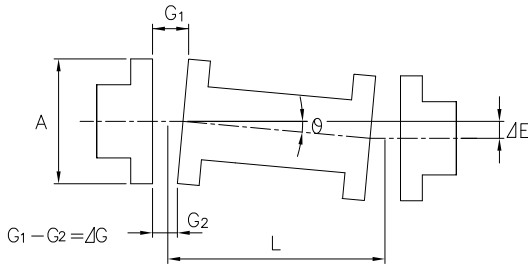

[Fig.3]

Shaft misalignment

- Shaft misalignment (θ and ΔE) causes lateral runout (ΔG) of the coupling.
- The related formula is as follows (refer to Fig 3)

$$\Delta E = L \tan\theta, \theta = \tan^{-1} (\Delta E / L)$$

$$\Delta G = A \tan\theta, \theta = \tan^{-1} (\Delta G / A)$$

- For angular misalignment and lateral runout, please align shafts not more than the values shown in Table 1.

Table 1

Type	Angular Misalignment	Content	Lateral runout(ΔG)TIR(mm)										
			405	410	415	420	425	430	435	440	445	450	455
4Bolt	0.1°	Size	405	410	415	420	425	430	435	440	445	450	455
		tolerance	0.12	0.15	0.16	0.2	0.22	0.25	0.29	0.34	0.37	0.43	0.48
6Bolt	0.07°	Size	601	602	603	604	605	610	615	620	-	-	-
		tolerance	0.12	0.15	0.18	0.21	0.24	0.27	0.3	0.34	-	-	-
8bolt	0.05°	Size	815	820	825	830	840	850	860	870	-	-	-
		tolerance	0.26	0.3	0.34	0.38	0.42	0.47	0.5	0.6	-	-	-

※ TIR : Dial gauge value

Installation

Nut tightening torque

Table 2

Size	405	410	415	420	425	430	435	440	445	450	455
Nut Nominal size	M6	M6	M8	M8	M10	M12	M12	M16	M16	M18	M24
Tightening torque(Nm)	9	9	22	22	41	72	72	160	160	220	570
Size	601	602	603	604	605	610	615	620	-	-	-
Nut Nominal size	M6	M8	M10	M12	M14	M16	M18	M20	-	-	-
Tightening torque(Nm)	9	22	41	72	86	160	220	320	-	-	-
Size	815	820	825	830	840	850	860	870	-	-	-
Nut Nominal size	M20	M22	M24	M30	M33	M36	M36	M42	-	-	-
Tightening torque(Nm)	320	440	570	1,100	1,500	1,700	1,700	3,000	-	-	-

General information

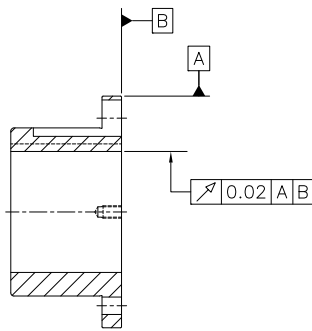

Assembly

- Make sure there is no lateral runout due to pack set deformation during assembly. In case lateral runout occurred, realign the shafts after disassemble the pack set.
- In case customer himself performs inner bore machining, perform it after aligning the concentricity and squareness.

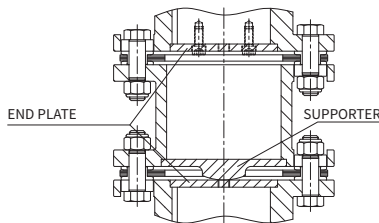

Vertical Installation

- Couplings are designed for horizontal installation.
- For vertical mounting a spacer supporter and end plates should be added.

Machining of inner bore & keyway

- NARA Panflex couplings shall be supplied with an assembled condition after machining inner bore and keyway.
- If inner bore and keyway machining is not required, contact NARA.

Balancing

- NARA Panflex coupling can be balancing-worked according to customer's requirements. Contact NARA if necessary.
- The standard couplings are not balancing-worked, In case of exceeding max. unbalanced speed, it should be balancing-worked.

Safety regulations

- Accidents may occur due to damage of coupling parts when being overloaded, etc. Make sure to install personal protection cover over ther couplings.

Application

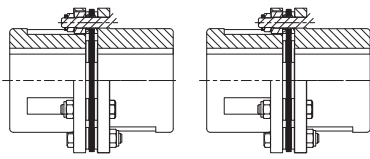
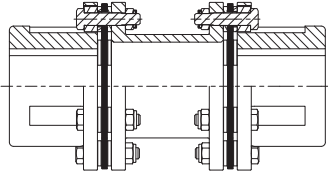
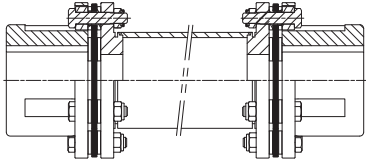
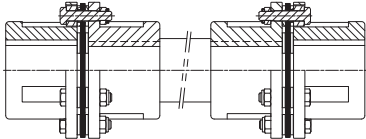
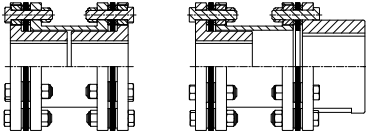
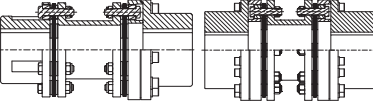
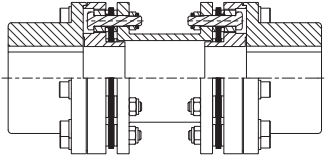
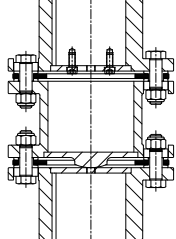
Type	Features	Application
<p>NPA Type</p> 	<ul style="list-style-type: none"> • Single element • Only angular misalignment and axial displacement allowed • High torsional rigidity • Compact design 	<p>Refer to information for installation on page 25.</p>
<p>NPB Type</p> 	<ul style="list-style-type: none"> • Two elements • Easy to absorb shafts misalignment • NPB standard type available in stock 	<ul style="list-style-type: none"> • Mixer • Stirrer • Pump • Fan • Devices with large radial loads
<p>NPS Type</p> 	<ul style="list-style-type: none"> • Spacer length is decided by customer • Welded pipe • High torsional rigidity • Dynamic balancing 	<ul style="list-style-type: none"> • Mixer • Stirrer • Pump • Fan • Devices with large radial loads
<p>NPS Type</p> 	<ul style="list-style-type: none"> • Spacer length is decided by customer • Assembly of NPA type 2 sets to the intermediate shaft 	<ul style="list-style-type: none"> • Mixer • Stirrer • Pump • Fan • Devices with large radial loads
<p>NPB-S/NPB-D Type</p> 	<ul style="list-style-type: none"> • Size reduced Hub • Compact, two elements • Assembly thru lateral side of spacer is not possible • For Replacement of Gear Couplings 	<ul style="list-style-type: none"> • Mixer • Stirrer • Pump • Fan • Devices with large radial loads
<p>NPE-A/NPE-B Type</p> 	<ul style="list-style-type: none"> • Compact, two elements • For Expansion of inner bore 	<ul style="list-style-type: none"> • Mixer • Stirrer • Pump • Fan • Devices with large radial loads
<p>NPE-B API Type</p> 	<ul style="list-style-type: none"> • Two elements • Standard spacer applied 	<ul style="list-style-type: none"> • Pump • Pump with API standard • Turbine
<p>NPV Type</p> 	<ul style="list-style-type: none"> • Vertical mounting • Available for long DBSE ※ Contact NARA 	<ul style="list-style-type: none"> • Vertical Pumps • Agitator

Размеры

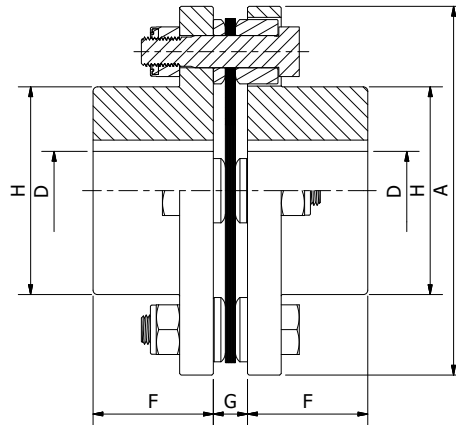
NPA
Single element

Size	Rated Torque (Nm)	Max speed (rpm)		Dimensions(mm)					Mass (kg)	Moment of inertia (kgm ²)
		Unbalanced	Balanced	Max. D	A	F	G	H		
405	33	5,000	15,000	23	67	25	6.1	33	0.6	0.00013
410	90	5,000	15,000	32	81	25	6.6	46	1.1	0.00033
415	177	5,000	15,000	35	93	29	8.4	51	1.7	0.00065
420	245	5,000	15,000	42	104	34	11.2	61	2.5	0.0012
425	422	4,400	12,000	50	126	41	11.7	71	4.3	0.003
430	775	4,000	10,000	58	143	48	11.7	84	6.8	0.0063
435	1,270	3,600	9,300	74	168	57	16.8	106	12	0.014
440	2,060	3,000	8,000	83	194	64	17	119	17	0.028
445	3,330	2,800	7,300	95	214	76	21.6	137	25	0.048
450	4,900	2,200	6,300	109	246	89	23.9	157	37	0.093
455	6,370	2,000	5,600	118	276	102	27.2	170	53	0.17

1. The standard couplings are not balancing-worked, In case of exceeding max. unbalanced speed, it should be balancing-worked.
2. For selection of NPA type, refer to installation guide on page 25. contact NARA if necessary
3. Mass and moment of inertia are values without bore's machining.

Размеры

NPB

Standard spacer

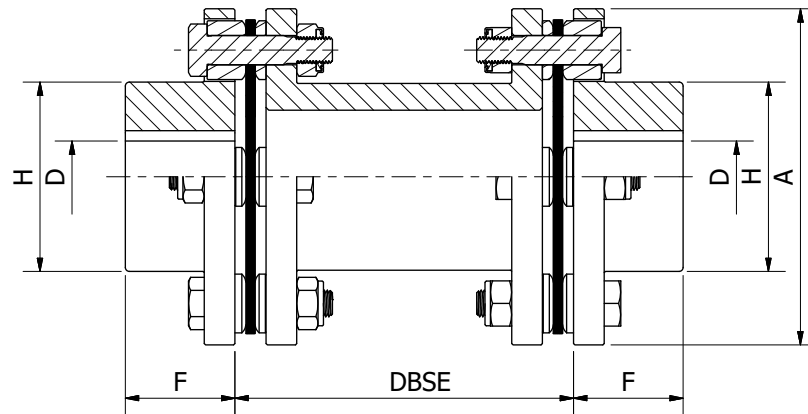

Size	Rated Torque (Nm)	Max speed (rpm)		Dimensions(mm)					Mass (kg)	Moment of inertia (kgm ²)
		Unbalanced	Balanced	max. D	A	F	DBSE	H		
405	33	5,000	15,000	23	67	25	90	33	0.6	0.0003
410	90	5,000	15,000	32	81	25	90	46	1.1	0.0008
415	177	5,000	15,000	35	93	29	100	51	1.7	0.0017
420	245	5,000	15,000	42	104	34	130	61	2.5	0.003
425	422	4,400	12,000	50	126	41	130	71	4.3	0.008
430	775	4,000	10,000	58	143	48	130	84	6.8	0.015
435	1,270	3,600	9,300	74	168	57	130	106	12	0.036
440	2,060	3,000	8,000	83	194	64	140	119	17	0.073
445	3,330	2,800	7,300	95	214	76	150	137	25	0.118
450	4,900	2,200	6,300	109	246	89	180	157	37	0.218
455	6,370	2,000	5,600	118	276	102	180	170	53	0.42

1. The standard couplings are not balancing-worked, In case of exceeding max. unbalanced speed, it should be balancing-worked.
2. "DBSE" can be manufactured according to customer's requirements.
3. Mass and moment of inertia are values without bore's machining.

Размеры

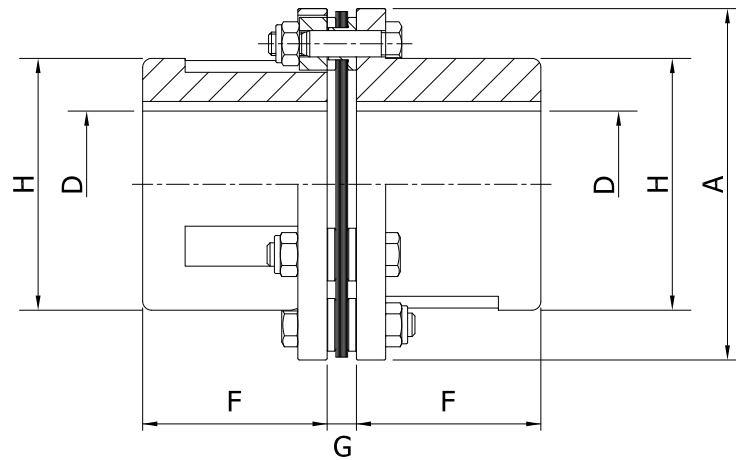
NPA
Single Element Boss Extension Type

Size	Rated Torque (Nm)	Max speed (rpm)		Dimensions(mm)					Mass (kg)	Moment of inertia (kgm ²)
		Unbalanced	Balanced	max. D	A	F	G	H		
601	451	5,000	15,000	47	95	54	7.5	66	3.1	0.003
602	903	4,400	12,500	62	120	63	10	86	6.5	0.01
603	1,730	4,200	11,000	75	145	74	12	103	11	0.025
604	2,630	4,000	10,000	92	175	80	14	128	17	0.06
605	5,250	3,500	9,000	104	197	95	16	144	25.7	0.12
610	8,090	3,200	8,500	118	226	108	17	164	37.1	0.24
615	11,550	3,000	8,000	129	247	121	18	180	51.8	0.38
620	15,750	2,800	7,000	145	276	134	19	202	72.8	0.68
815	18,480	2,300	7,000	141	296	137	19	196	70	0.72
820	30,030	2,200	6,000	164	337	163	23.2	229	113.4	1.65
825	42,000	2,000	5,300	188	386	186	24.5	262	168.7	3
830	60,165	1,800	5,000	208	427	206	27	289	230.3	4
840	90,300	1,600	4,500	241	486	240	29.5	336	331	7
850	120,700	1,400	4,000	264	536	265	34	367	469	13

1. The standard couplings are not balancing-worked, In case of exceeding max. unbalanced speed, it should be balancing-worked.
2. For selection of NPA type, refer to installation guide on page 25. contact NARA if necessary
3. Mass and moment of inertia are values without bore's machining.

Размеры

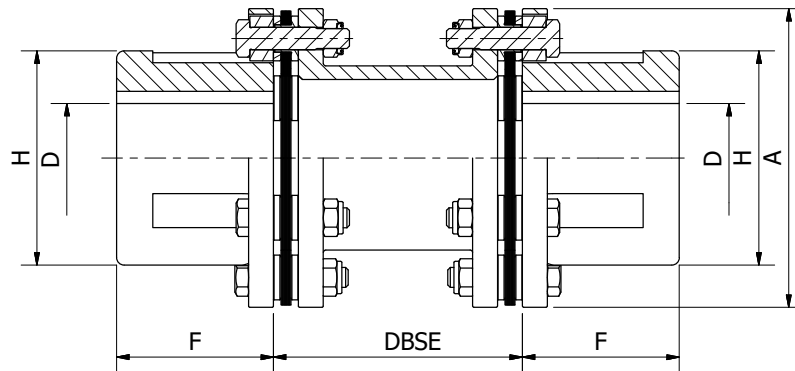
NPB
Standard Spacer

Size	Rated Torque (Nm)	Max speed (rpm)		Dimensions(mm)										Mass (kg)	Moment of inertia (kgm ²)
				Unbalanced	Balanced	max D	A	DBSE					F		
		minimum length	100					140	180	200	250				
601	451	5,000	15,000	47	95	100	○	○	○			54	66	According to customer specification	
602	903	4,400	12,500	62	120	100	○	○	○			63	86		
603	1,730	4,200	11,000	75	145	100	○	○	○			74	103		
604	2,630	4,000	10,000	92	175	100	○	○	○			80	128		
605	5,250	3,500	9,000	104	197	140		○	○			95	144		
610	8,090	3,200	8,500	118	226	140		○	○			108	164		
615	11,550	3,000	8,000	129	247	140		○	○			121	180		
620	15,750	2,800	7,000	145	276	180			○	○		134	202		
815	18,480	2,300	7,000	141	296	180			○	○		137	196		
820	30,030	2,200	6,000	164	337	180					○	163	229		
825	42,000	2,000	5,300	188	386	180					○	186	262		
830	60,165	1,800	5,000	208	427	250			300			206	289		
840	90,300	1,600	4,500	241	486	250			300			240	336		
850	120,700	1,400	4,000	264	536	250			350			265	367		
860	143,000	1,200	3,500	288	571	250			350			290	403		
870	238,000	1,000	3,000	347	683	300			400			350	486		

1. The standard couplings are not balancing-worked, In case of exceeding max. unbalanced speed, it should be balancing-worked.

2. "DBSE" can be manufactured according to customer's requirements.

Размеры

NPS

Long spacer & Intermediate shaft

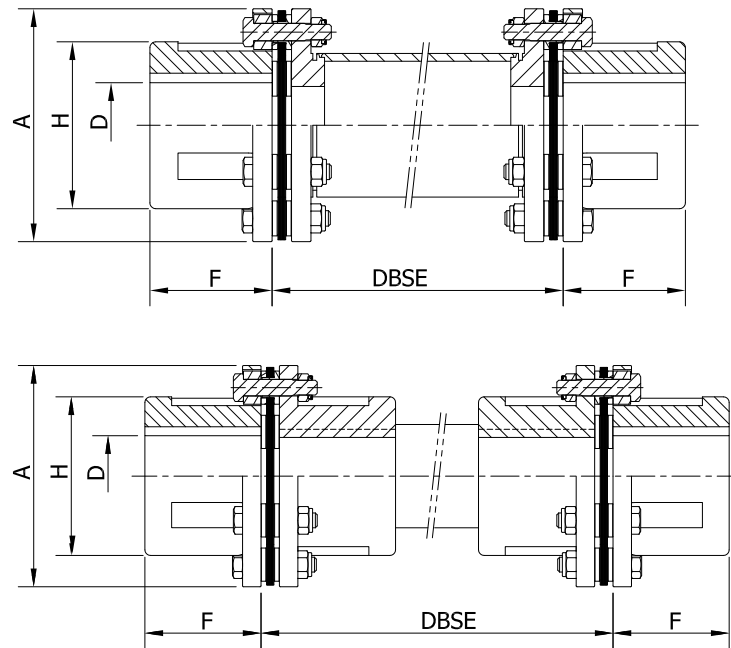

Size	Rated Torque (Nm)	Max speed (rpm)		Dimensions(mm)				
		Unbalanced	Balanced	max D	A	DBSE	F	H
601	451	According to customer specification (DBSE)		47	95	According to customer specification	54	66
602	903			62	120		63	86
603	1,730			75	145		74	103
604	2,630			92	175		80	128
605	5,250			104	197		95	144
610	8,090			118	226		108	164
615	11,550			129	247		121	180
620	15,750			145	276		134	202
815	18,480			141	296		137	196
820	30,030			164	337		163	229
825	42,000			188	386		186	262
830	60,165			208	427		206	289
840	90,300			241	486		240	336
850	120,700			264	536		265	367
860	143,000			288	571		290	403
870	238,000			347	683		350	486

1. The standard couplings are not balancing-worked, In case of exceeding max. unbalanced speed, it should be balancing-worked.
2. "DBSE" can be manufactured according to customer's requirements. .

Размеры

NPB-S

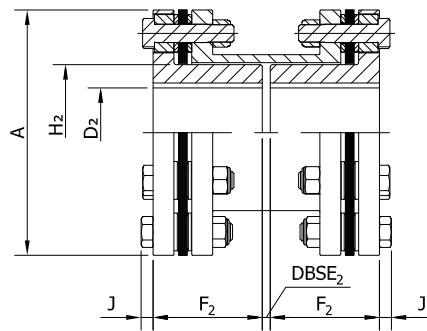

NPB-D

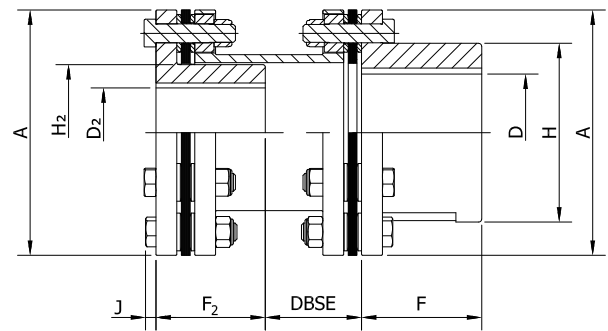

Size	Dimensions(mm)										NPB-S		NPB-D	
	D max	D ₂ max	A	F	F ₂	H	H ₂	J	DBSE	DBSE ₂	Mass (kg)	Moment of inertia (kgm ²)	Mass (kg)	Moment of inertia (kgm ²)
601	47	38	95	54	43	66	52.5	4	38	3	4.5	0.004	5	0.005
602	62	50	120	63	48	86	69	5.5	41	3	9.4	0.013	10.3	0.014
603	75	57	145	74	56	103	82	7	47.5	3	15.7	0.03	17.3	0.032
604	92	70	175	80	70	128	100	8	61	5	24.2	0.07	26.6	0.075
605	104	75	197	95	80	144	109	9	68	5	36.7	0.14	40	0.15
610	118	80	226	108	90	164	117	10	76	5	53	0.26	58	0.29
615	129	85	247	121	100	180	126	12	84	5	74	0.43	81	0.47
620	145	100	276	134	110	202	146	13	93	6	104	0.77	114	0.85
815	141	110	296	137	110	196	158	13	93	6	100	0.79	110	0.87
820	164	125	337	163	125	229	183	14	106	6	162	1.73	178	1.9
825	188	150	386	186	140	262	115	15	123	8	241	3.4	265	3.7
830	208	160	427	206	170	289	235	19	147	8	329	5.6	362	6.1
840	241	180	486	240	190	336	280	21	166	8	473	10.2	520	11
850	264	200	536	265	200	367	305	23	176	10	670	18	737	20

1. The standard couplings are not balancing-worked, In case of exceeding max. unbalanced speed, it should be balancing-worked.
2. "DBSE" can be manufactured according to customer's requirements.
3. Mass and moment of inertia are values without bore's machining.
4. Refer to NPB type on page 32 for rated torque & max. speed.

Размеры

NPE-A

One side Adaptor

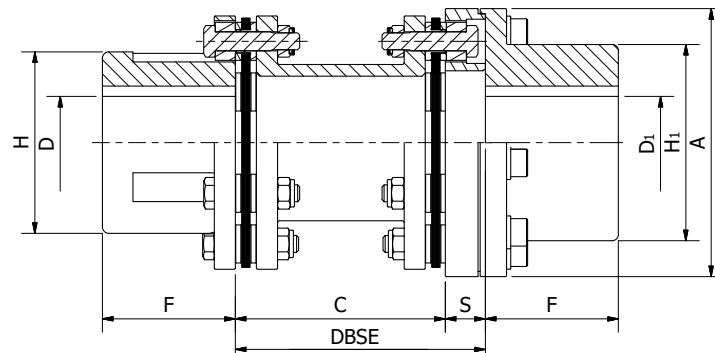

NPE-B

Both sides Adaptor

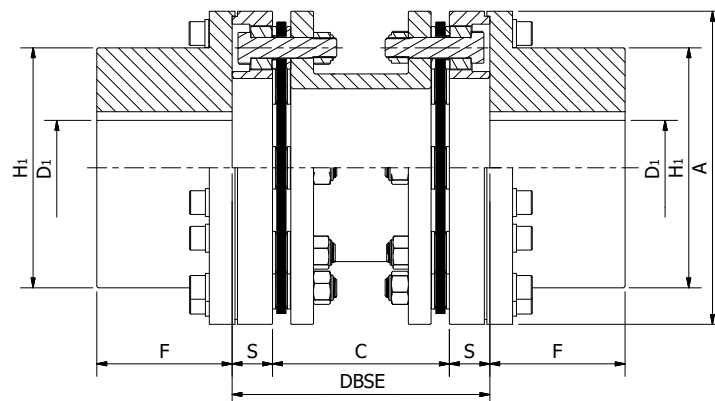

Size	Rated Torque (Nm)	Max speed (rpm)		Dimensions(mm)									Mass (kg)	Moment of inertia (kgm ²)
		Unbalanced	Balanced	max D	max D ₁	A	C	F	S	H	H ₁	DBSE		
												Min length		
601	451	5,000	15,000	47	55	100	80	54	15	66	76	130	6.6	0.007
602	903	4,400	12,500	62	68	127	100	63	19	86	93	138	13.2	0.024
603	1,730	4,200	11,000	75	88	154	100	74	23	103	120	146	23.1	0.06
604	2,630	4,000	10,000	92	104	193	100	80	26	128	145	152	37.1	0.16
605	5,250	3,500	9,000	104	117	211	140	95	30	144	163	200	53.4	0.28
610	8,090	3,200	8,500	118	128	244	140	108	34	164	178	208	75.2	0.49
615	11,550	3,000	8,000	129	147	270	140	121	38	180	204	216	110	0.9
620	15,750	2,800	7,000	145	166	296	180	134	41	202	230	262	150	1.5
815	18,480	2,300	7,000	141	181	317	180	137	41	196	243	262	164	1.9
820	30,030	2,200	6,000	164	210	357	180	163	45	229	285	270	250	3.7
825	42,000	2,000	5,300	188	241	433	180	186	49	262	335	278	403	8.6
830	60,165	1,800	5,000	208	268	470	250	206	57	289	366	364	545	13.8
840	90,300	1,600	4,500	241	298	536	250	240	60	336	414	370	800	25.4
850	120,700	1,400	4,000	264	324	600	250	265	70	367	450	390	1,120	45

1. The standard couplings are not balancing-worked, In case of exceeding max. unbalanced speed, it should be balancing-worked.
2. "DBSE" can be manufactured according to customer's requirements.
3. Mass and moment of inertia are values without bore's machining.

Размеры

NPE-B API

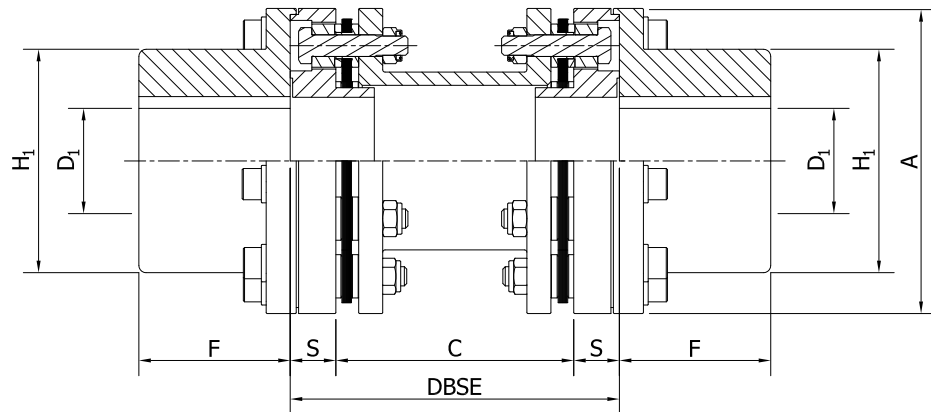

Size	Rated Torque (Nm)	Max speed (rpm)		Dimensions(mm)							Mass (kg)	Moment of inertia (kgm ²)
		Unbalanced	Balanced	max D ₁	A	C	F	S	H	DBSE Min length		
601	451	5,000	15,000	55	100	100	54	15	76	130	6.6	0.007
602	903	4,400	12,500	68	127	100	63	19	93	138	13.2	0.024
603	1,730	4,200	11,000	88	154	100	74	23	120	146	23.1	0.06
604	2,630	4,000	10,000	104	193	100	80	26	145	152	37.1	0.16
605	5,250	3,500	9,000	117	211	140	95	30	163	200	53.4	0.28
610	8,090	3,200	8,500	128	244	140	108	34	178	208	75.2	0.49
615	11,550	3,000	8,000	147	270	140	121	38	204	216	110	0.9
620	15,750	2,800	7,000	166	296	180	134	41	230	262	150	1.5
815	18,480	2,300	7,000	181	317	180	137	41	243	262	164	1.9
820	30,030	2,200	6,000	210	357	180	163	45	285	270	250	3.7
825	42,000	2,000	5,300	241	433	180	186	49	335	278	403	8.6
830	60,165	1,800	5,000	268	470	250	206	57	366	364	545	13.8
840	90,300	1,600	4,500	298	536	250	240	60	414	370	800	25.4
850	120,700	1,400	4,000	324	600	250	265	70	450	390	1,120	45

1. The standard couplings are not balancing-worked, In case of exceeding max. unbalanced speed, it should be balancing-worked.
2. "DBSE" can be manufactured according to customer's requirements.
3. Mass and moment of inertia are values without bore's machining.
4. This type is compliant with the API 610 and API 671 codes.



 **КУЗБАССТЕХНОСНАБ**
комплексные поставки промышленного оборудования

Являемся официальными представителями NARA на территории Российской Федерации. ООО «КТС» ОГРН 1215400048445
654063, Кемеровская область, г. Новокузнецк, ул. Шебелинская, д. 15

NARA ваш глобальный партнер

На протяжении последних 40 лет компания NARA прилагала все усилия для удовлетворения потребностей клиентов и поставляла все виды муфт по индивидуальному заказу для различных промышленных предприятий